

2. Radii to be R0.5 max unless otherwise specified.
1. Unless otherwise specified dimension are in millimeters tolerances on ± 0.1 , angle $\pm 1^\circ$.

Note

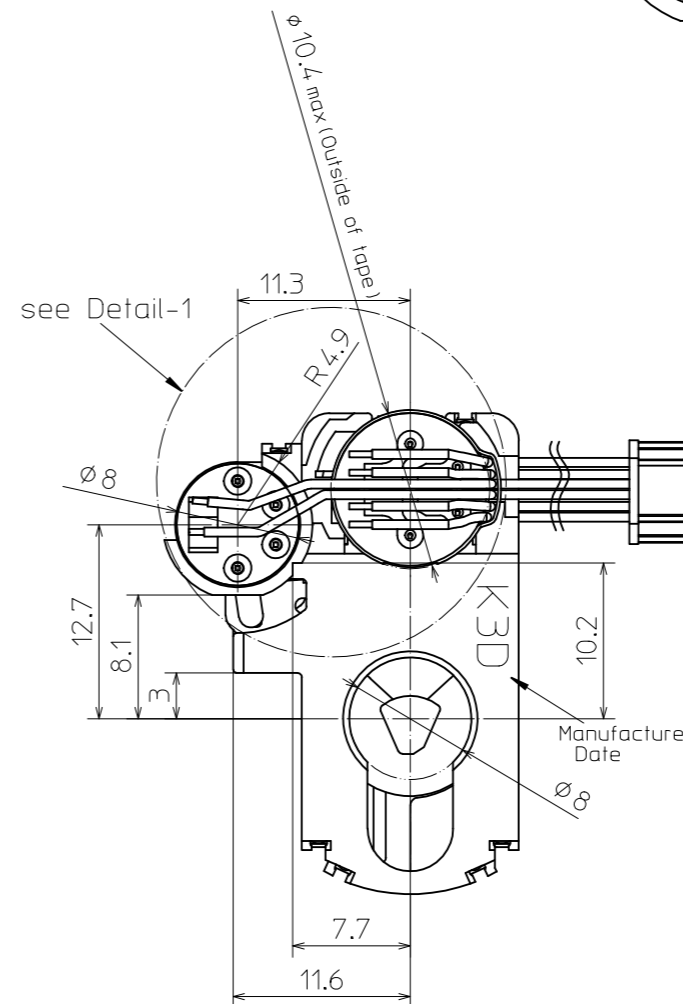

*Please specify the attachment method to a lens unit of a visitor.

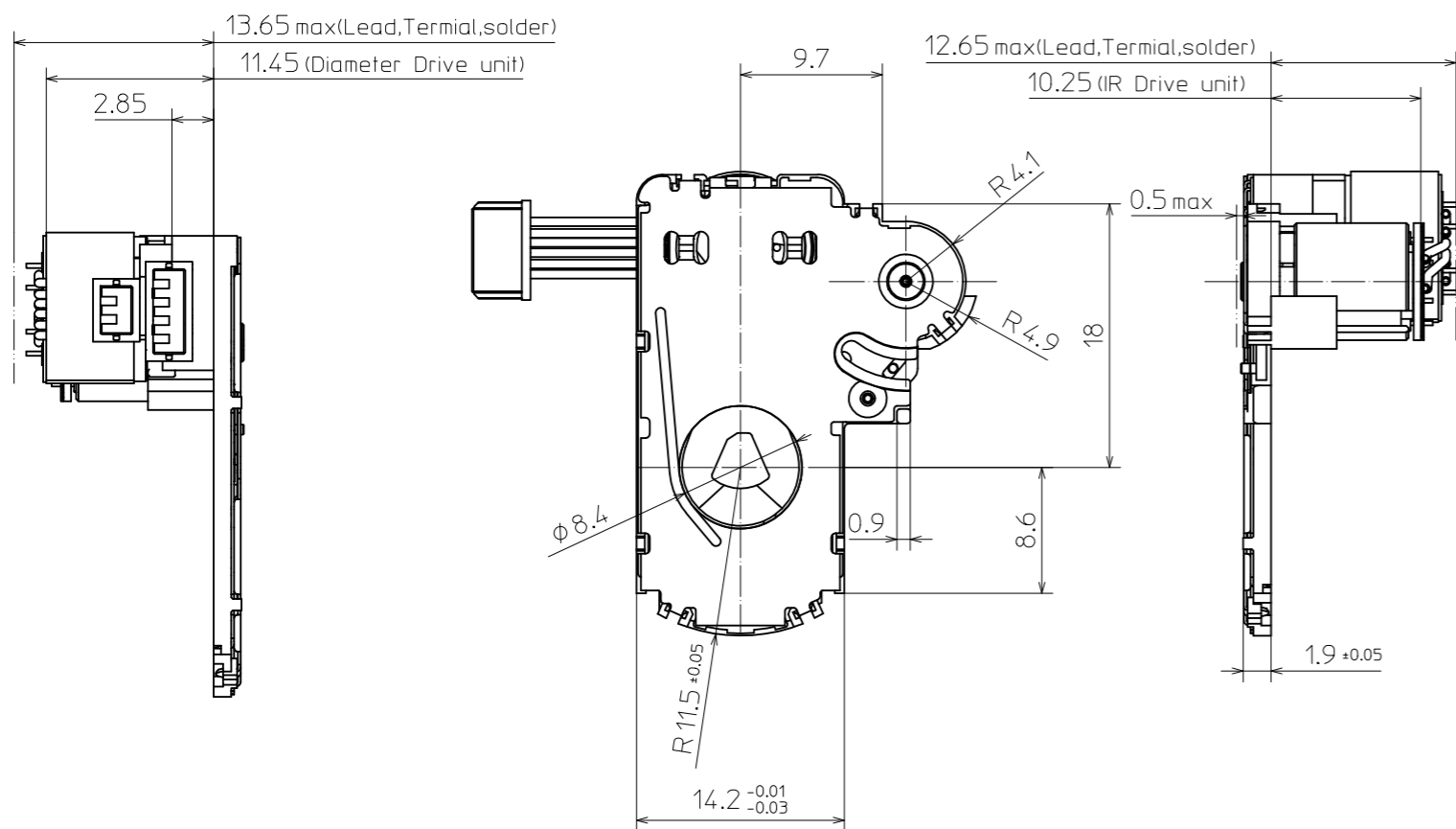
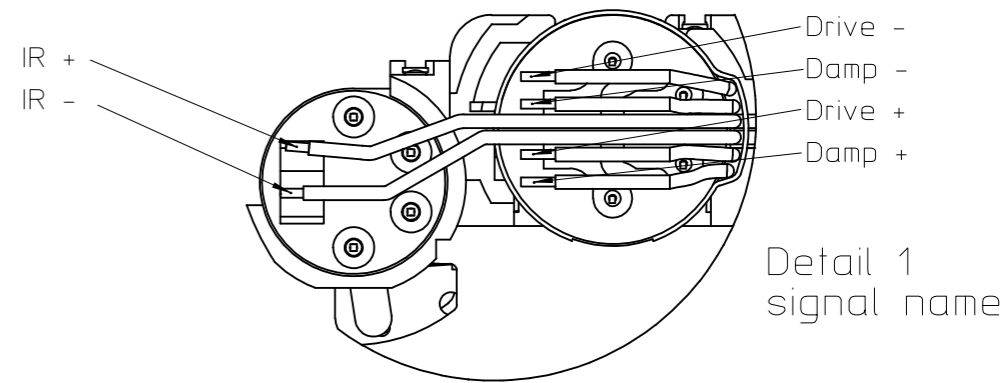
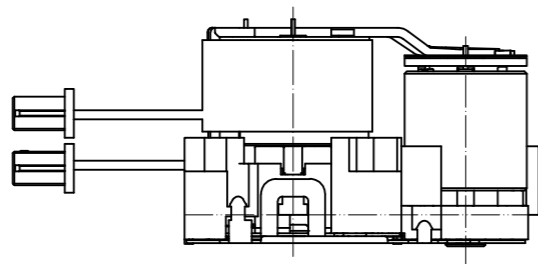
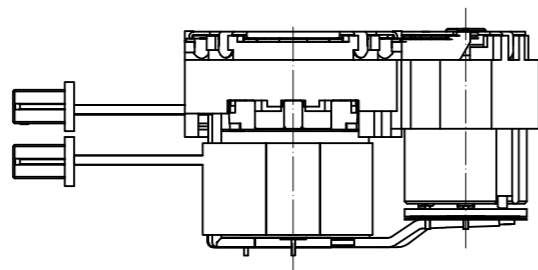

SURFACE TREATMENT		ANNEAL		SURFACE ROUGHNESS		SCALE 2:1	
						MATERIAL	
		DATE		NAME		MODEL-NAME	
		DRAWN				N80DNT	
		EXAM.					
		APPR.					
				New Asia Optical Industry		DRAWING-NUMBER	
						NA02-0000 -Ap/01	
INDEX	DESCRIPTION	DATE	NAME			SHEET	
						OF	